



Installation Manual

IPC upgrade kit 55 - 75
(95/155)

- 1 pcs. Control box (6 123...i)
- 1 pcs. Wiring loom (6 1226B)
- 1 pcs. Negative terminal / black cable (R10)

Upgrade procedure

1. Disconnect thruster batteries by disconnecting the mainswitch(es).
2. Disconnect the 4 way connector on the existing wiring loom (internal thruster wiring loom).
3. Disconnect the two cable connections on both sides of the solenoid (2 x red, 1 x blue and 1 x grey).
4. Loosen the middle bolt on top of the solenoid and remove the red cable.
5. Disconnect the 1 way connector on the thin wire coming out of the electric motor (over temperature function).
6. Remove existing wiring loom and control box.
7. Install the (R10) negative cable (included in kit) on the A1 terminal (battery negative) torque = 15 Nm.
8. Install the new control box (6 123...i) with the new wiring loom (6 1226B) on the existing holding bracket.
9. Connect blue, grey and red wires to the solenoid in accordance to the drawing on the next page.
Torque for the nut on B+ = 8 Nm.
10. Loosen A2 cable and install new white cable with circular cable shoe, between the spring washer and A2 cable.
Torque = 8 Nm.
11. Connect the black wire with the 1 way contact in the wiring loom, to the 1 way contact coming from A1 terminal.
12. Connect the brown wire with the 1 way contact in the wiring loom, to the 1 way contact coming from the electric motor (over temperature function).
13. Check that the connections are in accordance to the drawing on the next page.

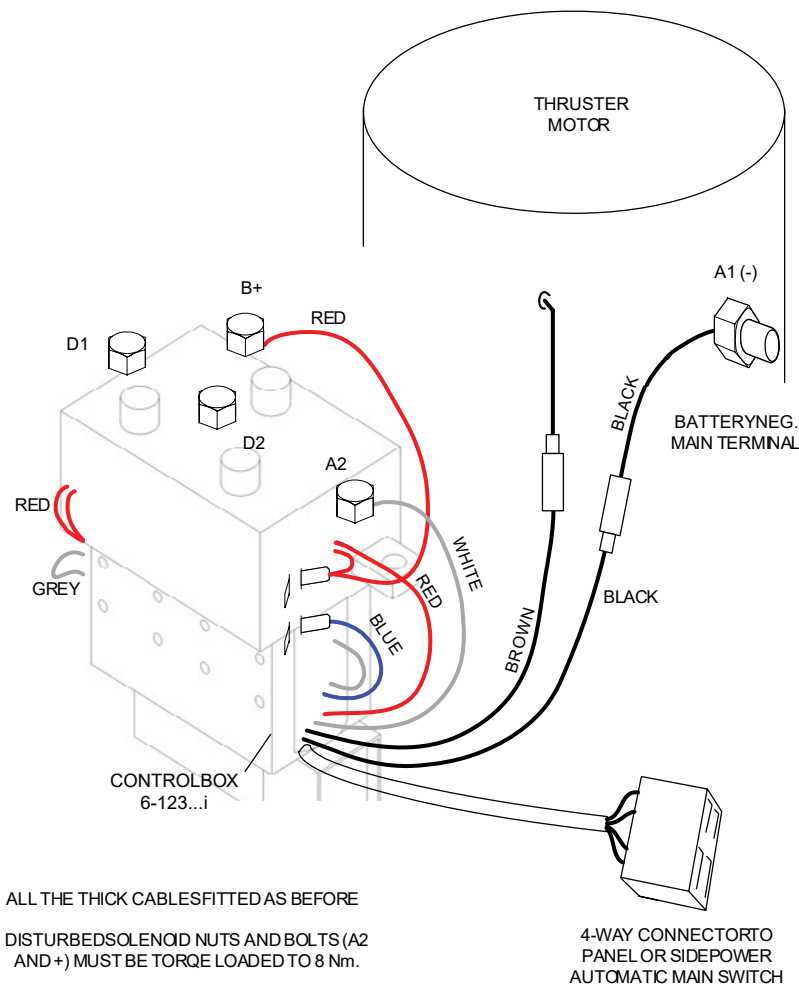

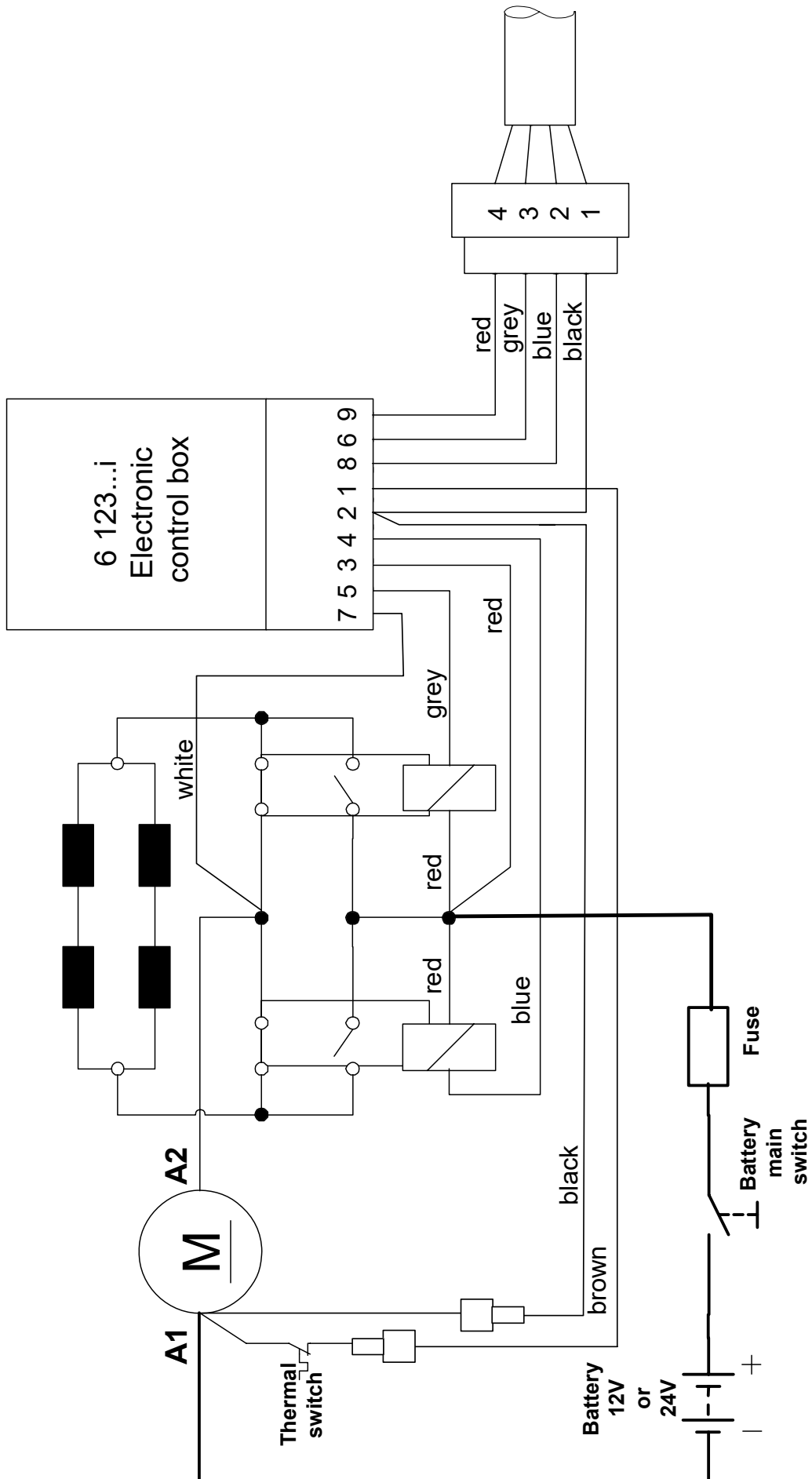

Introduction:

At Sleipner Group, we prioritize sustainability and encourage the repair and re-manufacturing of products to extend their life cycles. If disposal is necessary, please follow these guidelines to recycle and manage waste responsibly, ensuring our efforts align with environmental protection efforts.

Electric Motors and Electronics:

- Disconnect from any power sources and dismantle them carefully.
- Recycle components through certified e-waste recycling centers that can adequately handle and recover electronic materials.
- Dispose of any non-recyclable electronic parts according to local environmental regulations.

Metals:

- Collect and sort metal parts for recycling as scrap metal.
- To increase recycling efficiency, ensure that metals are clean and free from non-metal attachments.

Plastics:

- Identify recyclable plastics based on local recycling guidelines.
- Remove any non-plastic components and clean them before recycling to improve the quality of the recycled material.

Hazardous Materials:

- Correctly identify any hazardous substances within components, such as batteries or capacitors etc.
- Follow local regulations for the safe disposal of hazardous materials to prevent pollution and protect environmental health.

General Disposal Instructions:

- Consult local recycling programs to determine the acceptability of various materials.
- Use authorized disposal services to ensure compliance with environmental standards.

Safe Disposal Practices:

- Adhere to local laws and regulations for waste management to minimize environmental impact and ensure community safety.

This guide is designed to help reduce our products' environmental footprint through responsible end-of-life management. Please contact your local waste management supplier or our support team for more specific disposal information or further assistance.

MC_0848



SLEIPNER

Ocean born. Tech bred.

SLEIPNER MOTOR AS

P.O. Box 519

N-1612 Fredrikstad

Norway

www.sleipnergroup.com

Made in Norway

© Sleipner Motor AS, All rights reserved

The information given in the document was right at the time it was published. However, Sleipner Motor AS cannot accept liability for any inaccuracies or omissions it may contain. Continuous product improvement may change the product specifications without notice. Therefore, Sleipner Motor AS cannot accept liability for any possible differences between product and document. Learn more about our products at www.sleipnergroup.com